



EMERGENCY LIGHTING PRODUCTS

EMERGENCY LED DRIVER INSTALLATION AND OPERATING INSTRUCTIONS

ELP07-2060-UNV ELP10-2060-UNV-NC
ELP10-2060-UNV ELP14-2060- UNV

BEFORE BEGINNING INSTALLATION, READ THESE IMPORTANT SAFETY INSTRUCTIONS

IMPORTANT SAFEGUARDS

When using electrical equipment, basic safety precautions should always be followed including:

WARNING: Risk of fire or electric shock. Fixture wiring and electrical parts may be damaged when drilling for installation of LED Emergency Driver. Check for enclosed wiring and components.

WARNING: Risk of fire or electric shock. The LED Emergency Driver installation requires knowledge of luminaire electrical systems. If not qualified, do not attempt installation; contact a qualified electrician.

WARNING: Risk of fire or electric shock. The LED Emergency Driver is only for use with surface mount or recessed Type IC or Non-IC products listed to UL Standards. Suitable for use in damp locations and plenum spaces. Not for use in heated air outlets or hazardous locations.

WARNING: Risk of fire or electric shock. Do not alter, relocate or remove wiring, lampholders, power supply or any other electrical component.

WARNING: To prevent wiring damage and abrasion, do not expose wiring to edges of sheet metal or other sharp objects.

WARNING: Do not make or alter any open holes in the wiring enclosure or electrical component enclosure during installation. Only the open holes indicated in the instructions may be added or altered as a result of installation. Do not leave any other open holes in the wiring enclosure or electrical component enclosure during installation.

CAUTION: Before installing, make certain the AC power to the fixture is off.

CAUTION: Confirm there is 120-277V at the fixture before beginning installation.

CAUTION: To prevent electrical shock, only mate the unit connector after the installation is complete and before the AC power to the fixture is back on.

CAUTION: This fixture provides more than one power supply output source. To prevent electrical shock, disconnect both normal and emergency sources by turning off the AC branch circuit and disconnecting the unit connector.

CAUTION: Do not look directly at the LED light source for extended periods of time to prevent harm to eyes.

CAUTION: This is a sealed unit. Components are not replaceable. Replace entire unit when necessary.

CAUTION: This Emergency LED Driver requires an unswitched AC power source of 120-277V, 50/60 Hz. The AC LED driver MUST be on the same branch circuit as the Emergency LED driver.

CAUTION: Verify that the LED load requirements match/are compatible with the emergency driver selected.

CAUTION: Do not use outdoors.

CAUTION: Do not mount near gas or electric heaters.

CAUTION: Install in accordance with the National Electrical Code and regulations

CAUTION: Do not mount in locations or at heights in which the emergency driver could be tampered with by unauthorized personnel.

CAUTION: Do not use this equipment for anything other than its intended use.

CAUTION: Do not use accessory equipment not recommended by the manufacturer as this may cause an unsafe condition.

CAUTION: Use with grounded, UL Listed, damp location rated fixtures. Emergency Driver case should be grounded.

CAUTION: The equipment is intended for ordinary locations and for permanent installation into one or more Listed emergency luminaires.

The following are included:

PARTS	QUANTITY
LED Emergency Driver	1
Test Button	1
Tek Screws	2
Installation Guide	1
Luminaire Modification Label	1
Screw Wire Connectors	3
Wall Plate	1
Wall Plate Screws	2

Note: Installation requires application of the Luminaire Modification Label provided in your kit, as per UL. This label states: "This equipment has more than one connection point." This label must be applied to the fixture housing during installation.



EMERGENCY LED DRIVER: INSTALLATION AND OPERATING INSTRUCTIONS

Calculating Lumen Output During Emergency Operation

Evaluate luminaire/fixture data

i. DesignLights Consortium®

1. Log onto the DLC website (www.designlights.org).
2. Click on "search the DLC Qualified Product List" button on the DLC homepage.
3. In the "search by keyword" box enter: luminaire manufacturer and part number.
4. Click on "Search" tab to open the "Qualified Products List."
5. Determine per "RATED DATA" efficacy shown in lumens per watt (lm/w).
6. Multiply lumens per watt by ELP-2060 rated output (example: lm/w x 10 watts). Refer to table below for the wattage of the specific ELP-2060 model to be used in the luminaire. (lm/w) x (ELP-2060 watts) = nominal lumen output of fixture.

Part Number	Rated Output Power	Nominal Lumen Output*
ELP07-2060-UNV	7W	700 Lumens
ELP10-2060-UNV	10W	1000 Lumens
ELP10-2060-UNV-NC	10W	1000 Lumens
ELP14-2060-UNV	14W	1400 Lumens

*Nominal lumen output assumes fixture efficacy of 100 lumens/watt.

NOTE: Verification of these operating traits does not constitute a code-compliant emergency egress system. While the ELP-2060 Series has been found compliant with the requirements of UL 924, it is still the responsibility of the Designer/Specifier to assume appropriate light levels are achieved during emergency operation of the luminaire in accordance with Federal, State and Local municipal code regarding path of Egress Illumination.

Determining Adequacy of Means-of-Egress Lighting Levels

Follow industry standards by utilizing available .ies files and lighting design software for your dedicated emergency luminaires with the above calculated lumens and validate your as-installed plans in accordance with the applicable life safety codes governing your project.

INSTALLATION

Before beginning installation, verify the following:

- a. Read and understand all warnings and notes stated on page 1 before proceeding with installation.
- b. Verify the contents of the LED Emergency Driver installation kit contain the parts listed on page 1.
- c. Make sure the emergency driver characteristics match those of the fixture it is intended for installation with:
 - Verify that the existing LED driver is Class 2 compliant per the driver manufacturer specifications.
 - The fixture's driver must have an output power equal to or greater than the intended emergency driver.
 - The fixture's LED load voltage must be between 20-60VDC.
- d. Install in accordance with national and local electrical codes.

Mounting

Single-piece ELP emergency drivers are suitable for mounting on or adjacent to the fixture. Flex conduit A carries the emergency LED driver mains leads and the LED +/- leads. Connect flex conduit A from the emergency driver to a knockout on the fixture. Flex conduit B carries the battery connector leads and the test switch leads. Connect flex conduit B to a separate knockout in the fixture if the test switch will be installed in the fixture, or to a junction box external to the fixture if the test switch will be used on a wall plate. Do not mate the battery connectors until after power is applied.

For remote mounting of the emergency driver, the maximum recommended mounting distance is listed below. Remote mounting may result in power loss at the load, reducing the total lumen output.

Part Number	Rated Output Power	Maximum Mounting Distance
ELP07-2060-UNV	7W	20 ft
ELP10-2060-UNV	10W	22 ft
ELP10-2060-UNV-NC	10W	22 ft
ELP14-2060-UNV	14W	26 ft

EMERGENCY LED DRIVER: INSTALLATION AND OPERATING INSTRUCTIONS

Wiring

Connect wires per wiring diagram below according to application. Do not mate battery connector until all wiring is complete and power is restored. Wiring diagram for typical application that shares the fixture's LED load is seen below. For alternate application wiring diagrams see Hatch website at www.hatchlighting.com/led-emergency-drivers.

NOTE: Emergency driver housing must be grounded.

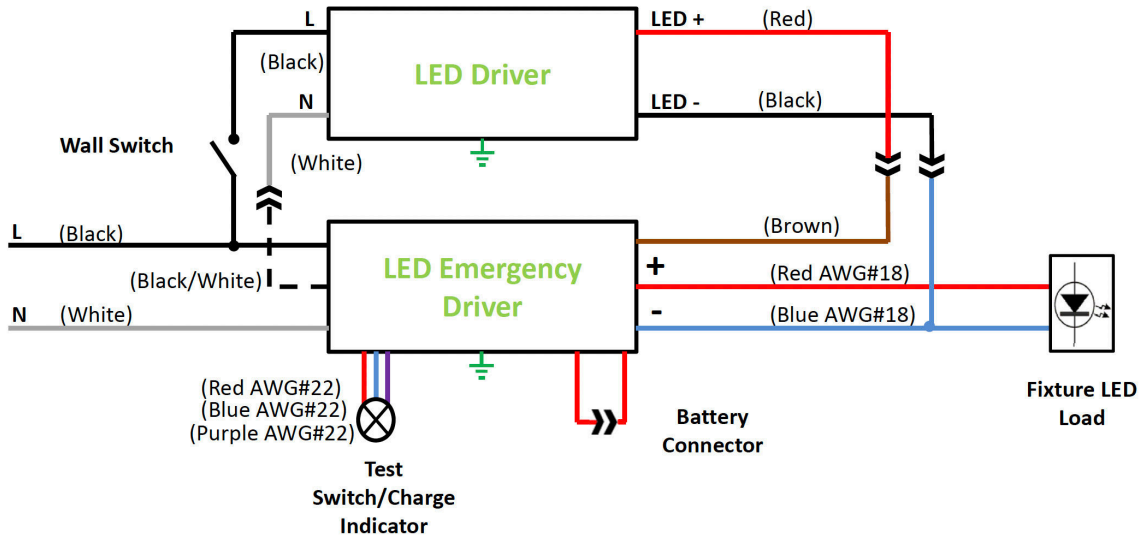

WIRING DIAGRAM - TYPICAL APPLICATION

OPERATION

Normal Mode: AC power is present. The AC driver operates the LED load as designed. The emergency pack is charging in a standby mode. The test button will be illuminated red, showing that AC power is present.

Emergency Mode: In the event of a power failure, the LED emergency driver switches to emergency mode and operates the fixture at the rated emergency driver output power level for a minimum of 90 minutes.

Testing Procedures

Prior to initial testing, allow unit to charge one hour. For 90 minute test, allow unit to charge for 24 hours.

- a. Press the test button to disconnect the power to the AC driver and switch the system to Emergency Mode. Release the test button to return to Normal Mode. Switch off the circuit breaker to simulate a full power outage.
- b. NFPA 101, Life Safety Code outlines the following testing schedule:
 - i. Monthly: Ensure that the test button light is illuminated. Conduct a 30 second discharge test by depressing the test button for 30 seconds. The LED load should operate at reduced output.
 - ii. Annually: Ensure that the test button is illuminated. Conduct a full 90-minute discharge test. The unit should operate as intended for the duration of the test.
 - iii. Written records of the testing shall be kept by the owner for inspection by the authority having jurisdiction.

Luminaire Modification Label

Make sure to adhere luminaire modification label to the fixture where it is easily visible to anyone servicing the fixture in the future.